

Application and Installation Instructions
3M NEQ-320
Heat Shrinkable
Nuclear Environmentally Qualified Tubing

Prepared by:

3M Canada Company
Technical Service
Electrical Markets Division

JULY 2001

Introduction

3M NEQ-320 Heat-Shrinkable Tubing has been specially formulated and designed for the environmental, mechanical and electrical protection of nuclear plant splicing applications up to and including 300 volts. Nuclear qualification testing has demonstrated the environmentally qualified performance of NEQ-320 while offering the shortest qualified seal length available.

To ensure that field applied NEQ-320 tubing performs as qualified, it is important that the application and installation instructions detailed in this document be carefully followed. Failure to do so may compromise the qualified performance of the NEQ-320 tubing. Performance of the NEQ-320 to qualification standards is contingent upon the substrate materials maintaining physical integrity under the same conditions utilized for qualification testing.

The tubing is identified by the printed legend "NEQ-320" followed by the expanded ID/recovered ID ratio, i.e. 19/6 - expanded ID= 19mm, recovered ID= 6mm.

Application Instructions

1) NEQ-320 Tubing Size Selection

Qualified performance of NEQ-320 tubing is dependant upon the selection of the proper size diameter tubing for a given application:

- a) wire splicing
 - determine the diameters of the insulated wires and the connector to be protected
 - determine the application range diameter from *Table 1* that covers these measured diameters
 - select the tubing size with this application range for this installation
- b) cable jacket re-establishment
 - determine the cable diameter
 - determine the application range from *Table 1* that covers these measured diameters
 - select the tubing size with this application range

Table 1: NEQ-320 Application Guide

Product	Application Range*		As Supplied I.D. (Min.)		Recovered I.D. (Max.)	
	inch	mm	inch	mm	inch	mm
NEQ-320-4/1	.043 - .134	1.1 - 3.4	.16	4.0	.04	1.0
NEQ-320-8/2	.083 - .177	2.1 - 4.5	.31	8.0	.08	2.0
NEQ-320-9/3	.122 - .240	3.1 - 6.1	.35	9.0	.12	3.0
NEQ-320-12/4	.165 - .327	4.2 - 8.3	.47	12.0	.16	4.0
NEQ-320-19/6	.248 - .492	6.3 - 12.5	.75	19.0	.24	6.0
NEQ-320-24/8	.326 - .650	8.3 - 16.5	.95	24.0	.31	8.0
NEQ-320-40/13	.531 - 1.181	13.5 - 30.0	1.57	40.0	.51	13.0

* When necessary NEQ-320 tubing can be used as a shim to increase wire/cable diameters for applications where individual tubing ranges do not meet diameter range requirements. The outer sealing sleeve will overlap the shim by at least 12mm.

2) Tubing Length Selection

Qualified performance of NEQ-320 tubing is dependent upon a minimum seal length of 1.65 inches (42 mm) over a qualified substrate (*See Figure 1*).

Total tubing length equals two times the minimum seal length plus the connection length. This determines the minimum length of tubing for a given application.

a) wire splicing

- determine the splice connection length for the wires to be joined - crimp barrel length plus bare conductor - Dimension A Figure 1
- locate connection length range in *Table 2* and select tubing length

b) cable jacket re-establishment

- determine the cable jacket connection length for the cable to be spliced Dimension E Figure 1 (also reference Dimension A Figure 2.)
- locate connection length range in *Table 2* and select tubing length

Table 2: Tubing Length Selection Guide

Connection Length (Dim. A or E Fig. 1) inch (mm)	Seal Length (Dim. B or D Fig. 1) inch (mm)	Tubing Length* (Dim C or F Fig. 1) inch (mm)
Up to 0.5 (13)	1.65 (42) minimum	4.5 (115)
0.5 - 1.5 (13 - 38)	1.65 (42) minimum	5.0 (127)
1.5 (38) and greater	1.65 (42) minimum	4.0 (102) + connection length

Dimensions are in inches (millimeters).

Connection Length refers to A or E in the following drawing.

* allows margin for installation positioning.

Installation Instructions

These instructions are to complete the typical installation shown in *Figure 1 - Typical Installation - 3 Conductor Cable with Ground* - using the tubing size and length selected per application instructions.

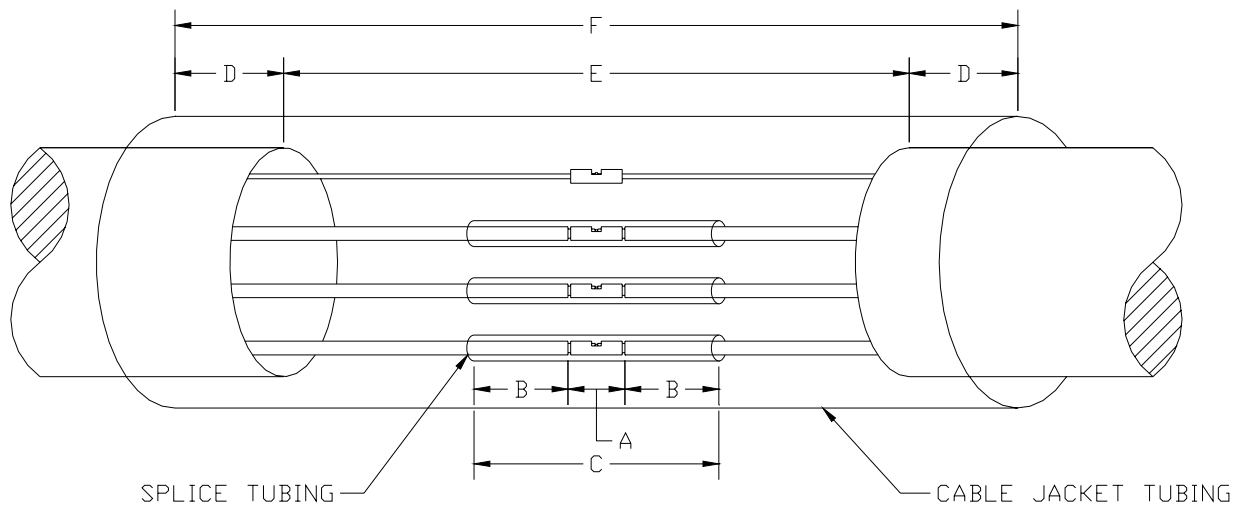

- A – Splice Connection Length
- B – Seal Length (Splice)
- C – Total Tubing Length (Splice)
- D – Seal Length (Cable Jacket)
- E – Cable Jacket Connection Length
- F – Total Tubing Length (Jacket Re-establishment)

Figure 1: Typical Installation - 3 Conductor Cable with Ground

Step 1 Prepare cable for splicing (See *Figure 2*) by removing all coverings down to wire insulation and stripping wire ends of insulation for crimp connection.

Note: Qualified performance of NEQ-320 tubing is contingent upon its installation over a smooth, non-porous, qualified substrate.

Step 2 Thoroughly clean all areas of wire/cable insulation to be covered by NEQ-320 tubing with a solvent approved for use by the wire/cable manufacturer

Step 3 Slide jacket tubing over cable and position away from connection area (See *Figure 2*). Be careful not to contaminate the inside adhesive layer of the tubing with foreign matter.

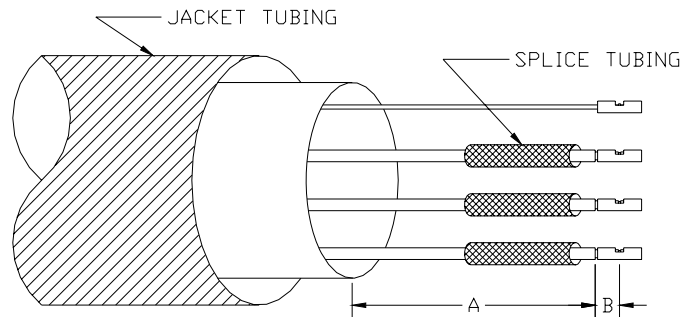

A – Ensure longer than splice tube length – Dimension C, Figure 1
B – Required length for crimp connection

Figure 2 - Tubing Positions (Splice and Jacket)

Step 4 Slide splice sleeves over wire (3 pieces) and position away from connection area (See *Figure 2*). Be careful not to contaminate the inside adhesive layer of the tubing with foreign matter.

Step 5 Complete connections using correct size connector and inspect for and remove any sharp edges or points with an abrasive cloth or file.

Step 6 Centre splice tubing over splice area ensuring that an equal seal length is provided on both sides of the connection (*See Figure 1*) and shrink with a soft open flame, propane torch or heat gun capable of heating the tubing over 250°F (121°C).

Shrink the tubing from the middle to the ends or from one end to the other to avoid the entrapment of air. Keep the heat source moving at all times to avoid damaging the tubing by overheating, which can cause scorching and charring of the surface.

Step 7 Centre jacket tubing over the spliced area ensuring that an equal seal length is provided on both sides of spliced area (*See Figure 1*) and shrink with a soft open flame, propane torch or heat gun capable of heating the tubing over 250°F (121°C).

Shrink the tubing from the middle to the ends or from one end to the other to avoid the entrapment of air. Keep the heat source moving at all times to avoid damaging the tubing by overheating, which can cause scorching and charring of the surface.

NOTE: Complete installation is indicated by a smooth wrinkle free tubing surface and the appearance of the melted sealant around the entire circumference of the wire/cable at each end of the tubing.

*Recommended heat guns: HL1810S, HL1910E, HL2010E or equivalent

NEQ-320 Removal

If for whatever reason the jacket sleeve or splice sleeve must be removed, please follow these removal instructions:

Step 1 To remove NEQ-320 tubing score the tubing along its entire length with a sharp knife being careful not to cut into the underlying substrate.

Step 2 Apply even heat to the tubing until the score lines start to separate.

Step 3 Pull tubing away with pliers. If tubing resists removal, apply additional heat.

Step 4 Install new tubing following Installation Instructions. Note that it is not necessary to remove residual adhesive from substrate, however, be careful not to contaminate residual adhesive prior to installation of tubing.